

PRESOSTATOS ATEX



TECHNICAL DATA

Material	Zamac
IP rating	IP66 according to EN/IEC 60529
Temperature range	-20°C ... +60°C
Certificate	INERIS 04ATEX0007
Marking	For Tfluid < +65°C II 2 GD Ex d e IIC T6 Gb Ex tb IIIC T85°C Db
Rated thermal current	6 A
Insulation voltage	250 V
Contact block	Single-pole snap action NO+NC
Electrical connection	Screw terminal block, cable entry ISO M20 for cable Ø 8 to 13 mm
Short circuit protection	By fuse 6 A gG (gl) to be installed outside the Ex area
Hydraulic connection	1/4" gas female - Other on request

Pressure switch with display	Gauge	Setting range upper threshold (ph)	Fluids controlled	Possible differential (add to PB to get PH)		
				Min. low setting	Min. high setting	Max. high setting
XMLW-CM02T2S12	- 1 bar	- 1 ... - 0.14 bar	Hydraulic oils, water, air	0.13 bar	0.14 bar	0.8 bar
XMLW-C001R2S12	1 bar	0.05 ... 1 bar	Hydraulic oils, air	0.03 bar	0.04 bar	0.8 bar
XMLW-C001S2S12	1 bar	0.005 ... 1 bar	Water, corrosives fluids	0.03 bar	0.04 bar	0.8 bar
XMLW-C004B2S12	4 bar	0.3 ... 4 bar	Hydraulic oils, water, air	0.17 bar	0.15 bar	2.5 bar
XMLW-C004C2S12	4 bar	0.3 ... 4 bar	Corrosive fluids	0.17 bar	0.15 bar	2.5 bar
XMLW-C010B2S12	10 bar	0.7 ... 10 bar	Hydraulic oils, water, air	0.45 bar	0.70 bar	8 bar
XMLW-C010C2S12	10 bar	0.7 ... 10 bar	Corrosive fluids	0.45 bar	0.70 bar	8 bar
XMLW-C020B2S12	20 bar	1.3 ... 20 bar	Oil, water, air	0.7 bar	1 bar	11 bar
XMLW-C020C2S12	20 bar	1.3 ... 20 bar	Corrosive fluids	0.7 bar	1 bar	11 bar
XMLW-C035B2S12	35 bar	3.5 ... 35 bar	Hydraulic oils, water, air	1 bar	1.5 bar	22 bar
XMLW-C035C2S12	35 bar	3.5 ... 35 bar	Corrosive fluids	1 bar	1.5 bar	22 bar
XMLW-C070D2S12	70 bar	7 ... 70 bar	Hydraulic oils, air	4.5 bar	8.9 bar	60 bar
XMLW-C070E2S12	70 bar	7 ... 70 bar	Fresh water, sea water	4.5 bar	8.9 bar	60 bar
XMLW-C070N2S12	70 bar	7 ... 70 bar	Corrosive fluids	4.5 bar	8.9 bar	60 bar
XMLW-C160D2S12	160 bar	12 ... 160 bar	Hydraulic oils, air	9 bar	21 bar	110 bar
XMLW-C160E2S12	160 bar	12 ... 160 bar	Fresh water, sea water	9 bar	21 bar	110 bar
XMLW-C160N2S12	160 bar	12 ... 160 bar	Corrosive fluids	9 bar	21 bar	110 bar
XMLW-C300D2S12	300 bar	22 ... 300 bar	Hydraulic oils, air	16 bar	35 bar	240 bar
XMLW-C300E2S12	300 bar	22 ... 300 bar	Fresh water, sea water	16 bar	35 bar	240 bar
XMLW-C300N2S12	300 bar	22 ... 300 bar	Corrosive fluids	16 bar	35 bar	240 bar
XMLW-C500D2S12	500 bar	30 ... 500 bar	Hydraulic oils, air	19 bar	52 bar	340 bar
XMLW-C500E2S12	500 bar	30 ... 500 bar	Fresh water, sea water	19 bar	52 bar	340 bar
XMLW-C500N2S12	500 bar	30 ... 500 bar	Corrosive fluids	19 bar	52 bar	340 bar

XMLW-C010/C020/035/070/160/300/500

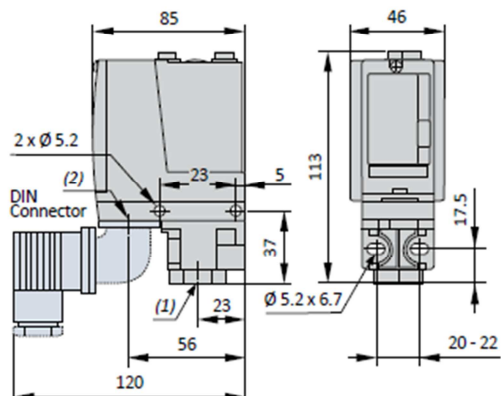

XMLW-C001

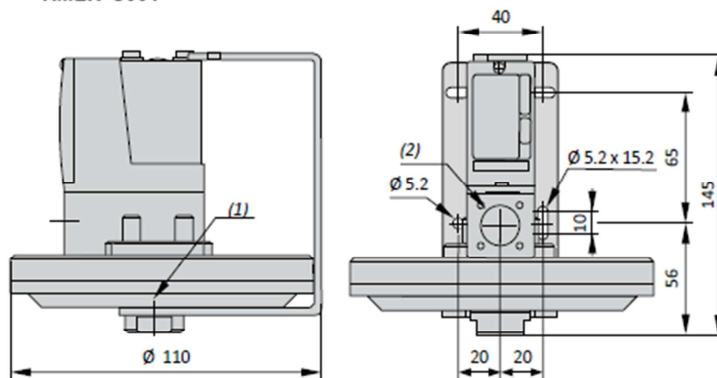

XMLW-CM02T2S12, XMLW-C004B2S12, XMLW-C004C2S12

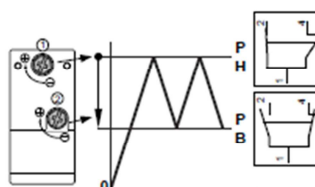
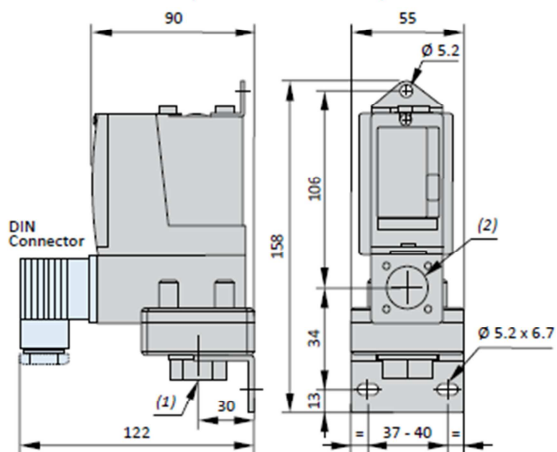

XMLW-C004B2S12,
XMLW-C004C2S12,
XMLW-C010 / C020 / 035
XMLW-070 / 160 / 300 / 500
XMLW-C001

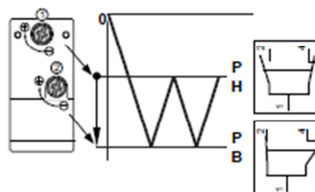

XMLW-CM02T2S12

- (1) Fluid entry G 1/4"
- (2) Electrical connection M20 x 1.5